



2025 ANNUAL CONFERENCE

5-7th September, 2025

Distinction Rotorua Hotel &
Conference Centre
390 Fenton Street Rotorua



Vision to Reality:
Innovative P&O Solutions



Sponsorship Proposal

2025 NZOPA Annual Conference

Vision to Reality:
Innovative P&O Solutions

Friday September 5, 2025 to
Sunday, September 7, 2025

Distinction Rotorua Hotel & Conference Centre
390 Fenton Street Rotorua

Contact

Website

www.nzopa.co.nz

Email

nzopa.conference@gmail.com
nzopa.adsup@gmail.com



Welcome

It is my pleasure to invite you and your organisation to the 13th Annual New Zealand Orthotic & Prosthetic Association (NZOPA) Conference. The premier event for Clinicians and Technicians providing Orthotic and Prosthetic services in New Zealand. Since 2009, the NZOPA has held an Annual Conference connecting you with our members from Northland to Southland. This year's theme is:

Vision to Reality: Innovative P&O Solutions

We are excited to extend the opportunity to providers in the O&P Industry to attend, display and/or present at this year's Conference. Our previous conferences have been very successful and we envision that this year's will be even better! For the first time, The NZOPA Annual Conference is aiming to create a specific programme for our Prosthetists, as well as the Orthotists.. We believe offering seperate content programming with attract more attendees, providing more opportunities for our exhibitors to connect with our members.

We are extending this invitation to your organisation to sponsor and exhibit. Our members work on the front line of the Orthotics & Porsthetics industry. This is a valuable opportunity for you to share how your information & products can improve patient and industry outcomes.

If you have any queries please don't hesitate to reach out.

Aashish Yamba
NZOPA Conference Executive



Meet the Conference Committee



Aashish Yamba

NZOPA Conference Lead



Hendrik Schoonwinkel

NZOPA President
Conference Committee



Jaska Stewart

NZOPA Website Exec
Conference Committee



Jess Starr

Admin Support



About The Venue



Your home of adventure located adjacent to the Whakarewarewa Forest offering world class mountain biking trails. With a beautiful garden setting, the affordable Distinction Rotorua Hotel is the perfect place to relax and unwind after enjoying the wealth of attractions and activities that Rotorua has to offer. Located minutes from the city centre and offering guests mountain bike facilities including a wash down facility as well as a purpose built, individual locker bike storage unit, FREE unlimited WiFi & complimentary guest car parking make the hotel a superb base for exploring the Rotorua area.

The hotel is a 15-minute drive from the airport. A taxi will cost around \$35 one way. Shuttles are also available.

We have secured over 750m2 for this year's conference. This year's floorplan has been developed with our exhibitors in mind. To maximise exhibitor visibility, this year's floorplan has been carefully considered knowing the importance of our exhibitor's interactions with our delegates. With multiple sponsorship packages and options, there is something to suit all budgets. New this year, our Platinum and Gold Sponsors will have additional accessories available for their booths.

Exhibitors can access the Exhibition hall for set up from 4pm on Thursday. Supplies can be sent to the venue in the 7 days leading up to the Conference. Space has also been reserved for those who need courier pick up on the Monday after pack out. If you do require further accessories for your booth, you can contact the venue hire company directly to organise.

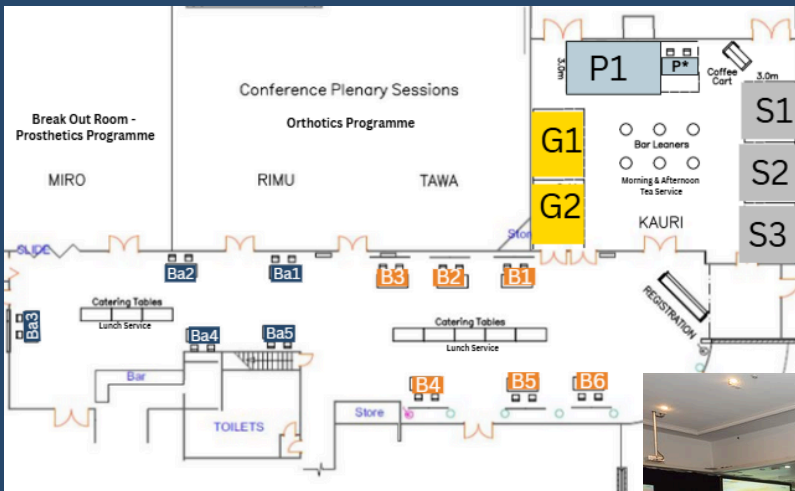



Platinum



NZOPA

Exhibitor Packages

Our most prestigious package

- Naming rights to the 2025 NZOPA Conference.
- Logo featured on Digital Conference Logos
- Logo featured on our Conference Sponsor Webpage
- **Massive 3 x 6m Exhibitor Space - 18 sqm**
- Positioned near morning & afternoon tea catering
- Plenty of space for signage, divider walls, power access
- Exclusive lunch buffet sponsorship
- Delegate table centerpiece for signage, brochures, etc.
- Video advertisement featured on Conference Webpage
- Up to FOUR flyers and two small products for delegate bags
- 4 Exhibitor passes (additional passes available \$250 each)
- PRE Conference delegate list
- Expand your exhibitor footprint & opportunities to connect with the delegates by adding the coffee cart for an additional \$2000 (see P* on the floorplan). Platinum gets first dibs before this opportunity is offered to everyone.

\$7,000 +GST



Gold

Two Premium Gold packages available

- Logo featured on our Conference Sponsor Webpage
- **Extra Large 4.2 x 3m Exhibitor Space - 12.6 sqm**
- near morning & afternoon morning tea catering
- space for signage, divider walls, power access and Free WiFi Access
- Advertisement featured on Conference Webpage - half page
- Up to THREE flyers and one small product for delegate bags
- 3 Exhibitor passes (additional passes available \$250 each)
- Post Conference delegate list

\$5,500 +GST

Exhibitor Packages



Silver

The Deluxe Silver Packages

- Logo featured on Conference Sponsor Webpage
- **Large 3 x 3m Exhibitor Space**
- near morning & afternoon morning tea catering
- space for signage, divider walls, power access and Free WiFi Access.
- Advertisement featured on the Conference Webpage – quarter page
- Up to TWO flyers and one small product for delegate bags
- 2 Exhibitor passes (additional passes available \$250 each)
- Post Conference delegate list

\$3,000 +GST



Bronze

Extra Bang for a Smaller Budget

- Logo featured on Conference Sponsor Webpage
- 1.8m Long Exhibitor Table
- High traffic location near lunch catering tables
- back wall, space for signage, power access and Free WiFi Access
- Advertisement featured on the Conference Webpage – eighth page
- ONE flyer for delegate bags
- 1 Exhibitor passes (additional passes available \$250 each)
- Post Conference delegate list

\$2,000 +GST



Basic

Great Choice for Smaller Organisations

- Logo featured on Conference Sponsor Webpage
- 1.8m Long Exhibitor Table
- High traffic location near lunch catering tables
- space for signage, power access & Free WiFi
- 1 Exhibitor pass (additional passes available \$250 each)

\$1,250 +GST

Additional Sponsorship Opportunities

**Welcome Drinks
& Platters
\$2,000 +GST**

Sponsor our popular Friday Evening Welcome Drinks and Platters. Your Company Name & Logo will be on all marketing for this event. Bring along extra signage to be placed at the bar!

**Saturday
Night Dinner
\$3,000 +GST**

Sponsor our Saturday Night Dinner. Your Company Name & Logo will be on all marketing for this event. Bring along extra signage to be placed at the dinner!

**Sponsored
Workshops –
Starting at
\$600 +GST**

Take this opportunity to position your company & products within the Conference Program! Present a hands on workshop spotlighting new products or technology. This presentation can be made to the Prosthetists, the Orthotists, or both! Reach out to Ash for availability & more info

**KeyNote
Speakers
\$2,000 +GST**

We have already secured one team from the UK for a hands on workshop, want to help support them, or another international speaker? Your support will be featured in all event advertisement.

**Name Tags &
Lanyards
\$500 +GST**

Sponsor NZOPA branded Lanyards & Conference Name tags. Your company name and logo will be featured on each attendee's name tag.

**Delegate
Bags
\$750 +GST**

Sponsor our delegate bags. Have your logo alongside NZOPA's logo on the delegate bag that each attendee receives and carries with them throughout the Conference

**Spot
Prizes**

Donate goodies for our spot prize drawings that will occur throughout the Conference. Your company logo will be on all marketing for the event. Please contact us for more information!

See floorplan below to plan your booth:

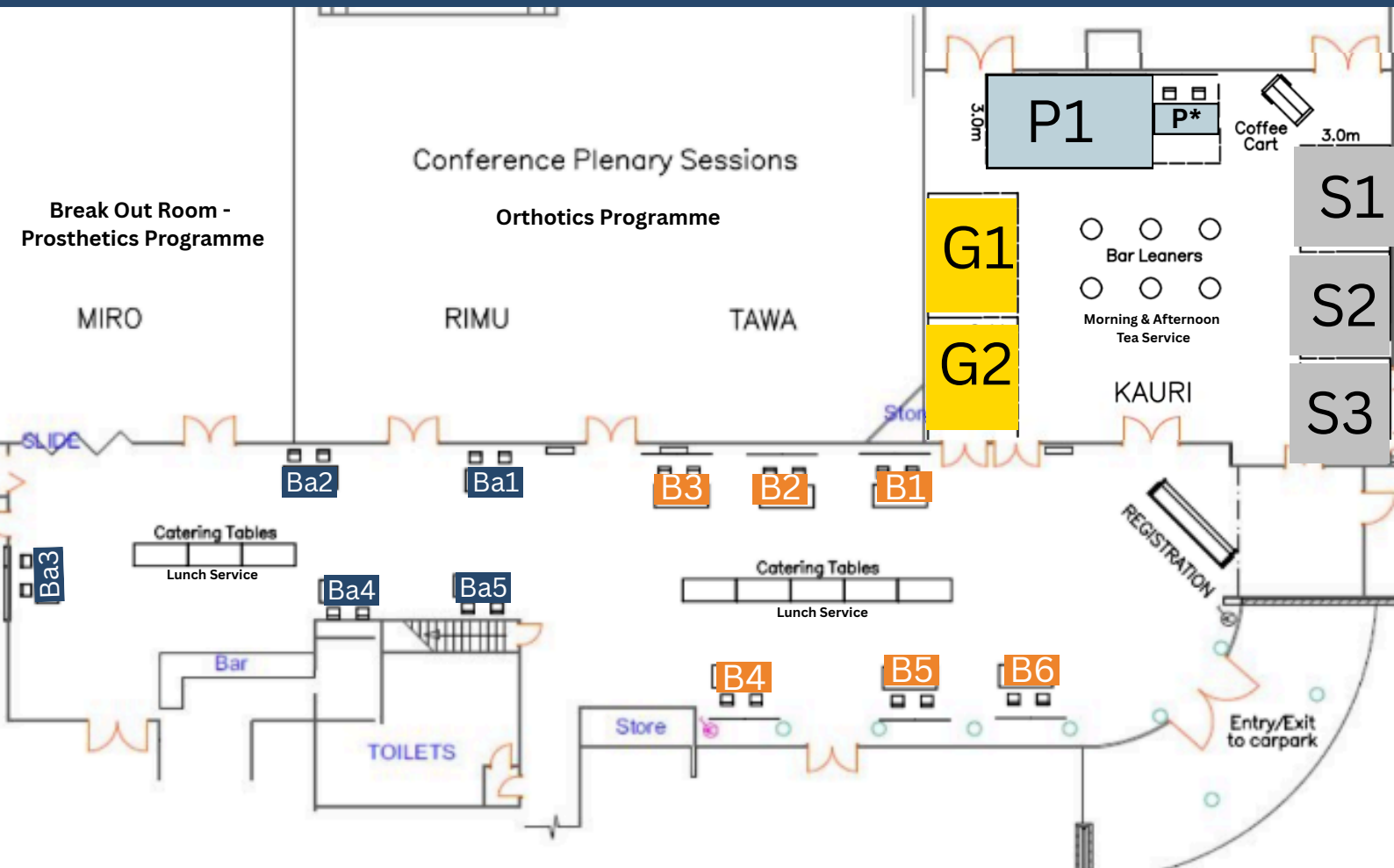

Exhibitor and Sponsorship Notes:

- *As an exhibitor, please ensure all booth signage and accessories fit **WITHIN** your allotted space or at your table. If you do require more space, please contact us and we can discuss options.*
- *By agreeing to any exhibitor or sponsor package, please note that you are agreeing to all terms as outlined, including branding, ad sizes, etc.*
- *Please ensure that all invoices are paid in full ahead of the conference.*



2025 ANNUAL CONFERENCE

5-7th September, 2025

Distinction Rotorua Hotel &
Conference Centre
390 Fenton Street Rotorua



Vision to Reality:
Innovative P&O Solutions



Thank you!

We Look Forward to Hearing From You!

Contact

Website www.nzopa.co.nz

Email nzopa.conference@gmail.com
nzopa.adsup@gmail.com